



Materials and Processes for NDT Technology second edition

Errata – first printing 01/16

The following text correction pertains to the second edition of *Materials and Processes for NDT Technology*. Subsequent printings of the document will incorporate the corrections into the published text.

The attached corrected page applies to the first printing 01/16. In order to verify the print run of your book, refer to the copyright page. Ebooks are updated as corrections are found.

Page	Correction
p. 39	In 2.4.3 Hexagonal Close-packed Structure, the first sentence in the second paragraph should read as follows: “The <u>FCC</u> and HCP are close-packed structures; that is, they are packed very efficiently with the highest possible packing factor of 0.74.”
p. 57	In the fourth full paragraph, the last line should read: “Grain size G is found from the equation” Equation 18 should read “2 to the power of G minus 1 Equation 19 has been replaced with the following: $G = (\ln[n] / \ln[2]) + 1$
p. 67	At the very bottom of the page: the left side of the equation should be B/H .
p. 90	In the paragraph on Martensitic Stainless Steel, the percentage range should be 11% to 18%.
p. 178	Figure 7.10: the label should read “Welding electrodes.”
p. 200	In the paragraph Joint Defined by Temperature and Spacing, the temperature should be 449 °C (840 °F).
p. 328	A shear wave in gold propagates at 1.2 km/s, not 3.1 km/s.
p. 356	The last sentence in the third paragraph should read: “Emissivity is inversely proportional to reflectivity and is a key variable in IR.”

The packing factor (PF_{FCC}) is:

$$\text{(Eq. 2.10)} \quad \frac{\text{volume of atoms}}{\text{volume of unit cell}}$$

This can be expressed as:

$$\text{(Eq. 2.11)} \quad \frac{\left(\frac{16}{3}\pi R^3\right)}{\left(\frac{4}{\sqrt{2}}R\right)^3} = 0.74$$

Larger packing factors mean that the FCC metals are more densely packed. Iron has an FCC structure at higher temperatures, and it weighs more per unit volume than at room temperature where it is more “loosely” packed in a BCC structure. Aluminum, copper, nickel, silver, lead, gold, and some other materials form FCC crystallographic structures. Some compounds, such as NaCl (table salt) also have the FCC structure. The unit cell may be viewed as an FCC structure of one type of atom, for example, Na, with the other, Cl, occupying the interstitial vacancies. Both elements for an FCC structure are intertwined.

2.4.3 HEXAGONAL CLOSE-PACKED STRUCTURE

A hexagonal close-packed (HCP) structure with the center of atoms represented as hard balls is shown in Figure 2.24a. The hard-ball representation of whole atoms is shown in Figure 2.24b. This structure represents three HCP unit cells, which are skewed prisms. As can be seen, each atom in one layer is located directly above or below the interstices created by the space between three adjacent atoms in neighboring layers. Atoms are touching along the side of the base. In an ideal HCP structure, $c/a = 1.633$, but for most HCP metals c/a ratios differ slightly due to the presence of mixed bonding conditions—metallic and some covalent.

The FCC and HCP are close-packed structures; that is, they are packed very efficiently with the highest possible packing factor of 0.74. Several metals have the HCP structure including zinc, magnesium, titanium, and cobalt.

2.4.4 AMORPHOUS STRUCTURES

As mentioned earlier, solids can be generally classified into two types: (1) crystalline, which can form a regular repeating three-dimensional structure called a crystal lattice, and (2) amorphous, which can aggregate with no particular order. The word *amorphous* is derived from Greek word “amorphos” meaning “without order.”

In an amorphous solid, the local environment, including both the distances to neighboring units and the numbers of neighbors, varies throughout the material. Different amounts of thermal energy are needed to overcome these different interactions. Consequently, amorphous solids tend to soften slowly over a wide temperature range rather than having a well-defined melting point like a crystalline solid. If an amorphous solid is maintained at a temperature just below its melting point for long periods of time, the component molecules, atoms, or ions can gradually rearrange into a more highly ordered crystalline form.

Amorphous solids include both natural and manufactured materials. The most frequently cited example of an amorphous solid is glass. However, amorphous solids are common to all subsets of solids. Additional examples include thin film lubricants, metallic glasses, polymers, and gels.

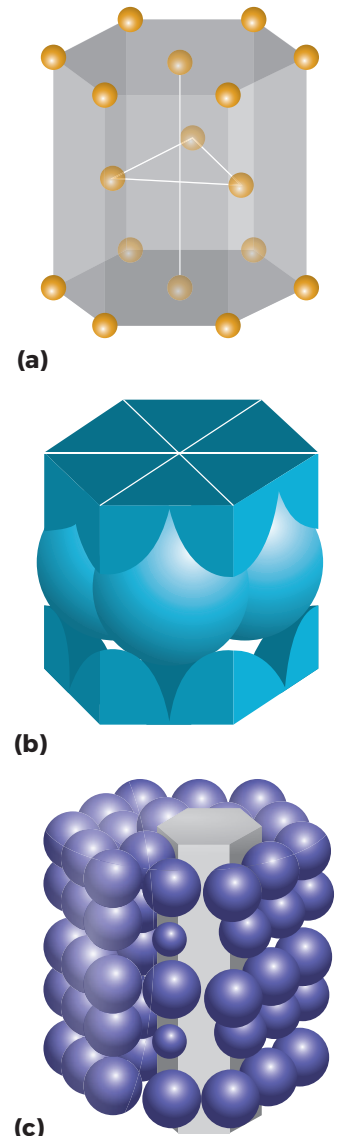

Figure 2.24: Schematics of hexagonal close-packed structure.

any particular grain, all of the unit cells are arranged with one orientation and one pattern. However, at the grain boundary, where two differently oriented crystals meet, there is a mismatch between the atoms as well as empty space (voids). This *grain boundary*, a two-dimensional imperfection, often runs to several layers of atoms.

We can locate grain boundaries using a metallurgical microscope. The piece of metal (in our discussion, we will use the example of metal from now on) is first smoothly polished so that a mirror-like surface is obtained and then chemically attacked for a short period of time. This process is called *etching*. The atoms on the grain boundary have more energy than atoms in the interior of the grain (the same way that atoms on the surface have), and they dissolve more readily in the acid, resulting in loose particles. When they are removed, grooves are left behind, making the grain boundary readily seen under an optical microscope.

Smaller grains have more grain boundaries per unit area. These grain boundaries stop dislocations by interrupting their slip plane. Materials with smaller grains are stronger at room temperature. Atoms can diffuse more easily in the material with smaller grains. Also, materials with small grains melt at lower temperatures because more energy is already stored in the grain boundary.

Since the grain boundary affects a material in a number of ways, it is useful to know the amount of grain-boundary surface per unit volume S_v . This area can be estimated if we place a line (straight or curved) randomly across the magnified picture of the piece of metal (or screen) with etched atoms. This line will intersect more of the grain boundary in a fine-grained material than in coarse-grained material. The relation is:

$$(Eq. 2.17) \quad S_v = 2P_L$$

where P_L is the number of points of intersections per unit length between the line and the boundaries.

A more common identification of the amount of grain boundary per unit area is *grain size* (n). A method to determine the grain size number has been standardized by ASTM International (formerly, the American Society for Testing and Materials). Although empirical, it is a quantitative and reproducible index. Grain size G is found from the equation:

$$(Eq. 2.18) \quad n = 2^{G-1}$$

Or:

$$(Eq. 2.19) \quad G = \frac{\ln(n)}{\ln(2)} + 1$$

where n is the number of grains per area of 1 in.² (0.0645 mm²) at magnification of 100×.

Grains are counted as one if they are completely inside of the area, 1/2 if they are cut by the line, and 1/4 if they are in the corners regardless of their size.

Number of Grains per Unit Area. Although there might be a little difference in n for different areas analyzed, the number of grains will come out the same (n is a rounded number). Only if you count two times more grains in one specimen than in

the hub clamps tightly against the shaft. This process, known as *autofrettage*, is applied on a number of products, especially those that experience high pressures, such as cannons and pressure vessels.

3.2.3 ELECTRICAL PROPERTIES OF MATERIALS

Electrical properties are defined as the response of materials to an applied electric field. They are important not only in designing circuitry, electrical machines, and electronic devices, but also in the selection of manufacturing processes and testing methods of products. For instance, electro-discharge machining (EDM) and electro-chemical grinding are used on hard-to-manufacture products, and electromagnetic testing (ET) is used on conductive materials.

Electrical conductivity is an expression of how well materials conduct electrical current. The opposite of electrical conductivity is *electrical resistivity*. The units that measure electrical resistivity are Ω/m (ohms per meter) or Ω/ft (ohms per foot) of the length of the specimen. Therefore, conductivity is measured in units of meter/ Ω or foot/ Ω . Materials with high conductivity are called *conductors*. Almost all pure metals are very good conductors. The conductivity of alloys is lower than that of pure metals. For instance, brass, which is a copper and zinc alloy, has a lower conductivity than pure copper and pure zinc. The reason for this is that the different atomic sizes of the two elements obstruct the passage of electrons within the matrix of the parent material. Metals with only metallic bonding and a uniform structure, such as copper, are better conductors than metals with mixed bonding, such as iron, which has metallic and partially covalent bonding. In covalent bonding, electrons are not free to move about to conduct electricity. Materials that are covalently bonded (for example, most ceramics) are called *resistors*. As mentioned in Chapter 2, there are materials that can conduct electricity under certain circumstances but not others. These materials are called *semiconductors*.

Under very high voltages, the resistivity of materials can be “broken.” The *dielectric strength* of materials is defined as the voltage per unit length necessary for electrical “breakdown”; that is, the material becomes a conductor of direct current. *Superconductivity* is a phenomenon whereby materials below some critical temperature exhibit zero electrical resistivity. Certain metals, a large number of intermetallic compounds (combinations of two or more metals), and some ceramics exhibit superconductivity at very low temperatures. The highest temperature at which this phenomenon is observed is now approximately 88 °C (190 °F). Materials with superconductivity at appreciably higher temperatures are constantly sought, since the use of these materials greatly improves the efficiency of electrical and electronic devices.

Some ceramics and quartz crystals exhibit the *piezoelectric effect* (from Greek *piezo-* meaning to “press”). In piezoelectricity, there is a reversible interaction between an elastic strain and electrical field. When these materials are compressed, they generate an electrical current, and when they are given an electric current, they undergo a change in dimension. This property is the foundation of ultrasonic transducers, precision actuators, sonar detectors, and some microphones.

3.2.4 MAGNETIC PROPERTIES

Magnetism refers to physical phenomena arising from the force between magnets—objects that produce fields that attract or repel other objects. The origin of magnetism lies in the orbital and spin motions of electrons and how the electrons interact with one another. In most atoms, electrons occur in pairs. These electrons spin in opposite directions resulting in a cancellation of the magnetic field or no net magnetic field.

Magnetic susceptibility (χ) is one of the main properties along with magnetic field strength (H) and magnetic flux (B): $\chi \propto B/H$.

group was first called *stainless steel*. With the emphasis on high temperature use, they are frequently referred to as *heat- and corrosion-resistant steels*.

Martensitic Stainless Steel. With lower amounts of chromium or with silicon or aluminum added to some of the higher chromium steels, the material responds to heat treatment much as any low alloy steel. The gamma-to-alpha transformation in iron occurs normally, and the steel may be hardened by heat treatment similar to that used on plain carbon or low alloy steels. Steels of this class are called *martensitic*, and the most used ones have 11% to 18% chromium.

Ferritic Stainless Steel. With larger amounts of chromium, as great as 30% or more, the austenite is suppressed, and the steel loses its ability to be hardened by normal steel heat-treating procedures. Steels of this type are called *ferritic* and are particularly useful when high corrosion resistance is necessary in cold-worked products.

Austenitic Stainless Steel. With high chromium and the addition of 8% or more of nickel or combinations of nickel and manganese, the ferrite is suppressed. These steels, the most typical of which contains 18% chromium and 8% nickel, are referred to as *austenitic stainless steels*. They are not hardenable by normal steel heat-treating procedures, but the addition of small amounts of other elements makes some of them hardenable by a solution precipitation reaction.

Composition and Structure Critical for Corrosion Resistance. In any stainless steel, serious loss of corrosion resistance can occur if large amounts of chromium carbide form. Consequently, the ferritic and austenitic grades are generally made with low amounts of carbon and even then may need special heat treatments or the addition of stabilizing elements such as molybdenum or titanium to prevent chromium carbide formation. With the martensitic grades in which the hardness and strength depend on the carbon, the steels must be fully hardened with the carbon in a martensitic structure for maximum corrosion resistance.

The austenitic steels are the most expensive but possess the best impact properties at low temperatures, the highest strength and corrosion resistance at elevated temperatures, and generally the best appearance. They are used for heat exchangers, refining and chemical processing equipment, gas turbines, and other equipment exposed to severe corrosive conditions. The austenitic steels are *paramagnetic* (practically unaffected by magnetic flux). This fact precludes the use of magnetic particle testing. In the as-cast state, and in welds, austenitic stainless steel is quite coarse-grained. In ultrasonic testing of this material, high levels of noise and attenuation serve to limit the effectiveness of the test.

Both the ferritic and martensitic stainless steels are magnetic. Most are not as corrosion resistant at high temperatures as the austenitic type but offer good resistance at normal temperatures. They are used for such products as cutlery, surgical instruments, automobile trim, ball bearings, and kitchen equipment.

Fabrication Difficult. The stainless steels are more difficult to machine and weld than most other ferrous materials. In no case can stainless steels be classed as the easiest to work, but they can be processed by all of the normal procedures, including casting, rolling, forging, and pressworking. Table 4.4 presents information on common forms of stainless steel.

4.1.9 CAST IRON

These simplest ferrous materials are produced by causing the molten metal to solidify into approximate final product form. The result is known as a casting. The processes of making castings is discussed in Chapter 6. Some of the relationships between common cast irons are shown in Table 4.5.

Resistance-Welded Tubing. Light-gage steel tubing in sizes up to 40 cm (16 in.) in diameter may be produced by *resistance welding* of stock that has been formed cold by rolls, which progressively shape the material from flat strip to tubular form. The general arrangement is shown in Figure 7.10. After forming, the tube passes between electrodes, through which welding current is supplied, and pressure rolls that maintain pressure in the weld area. Because the material is heated only locally, the pressure produces flash on both the inside and outside of the tube. The outside flash is removed by a form cutter immediately following the welding operation. The inside flash may be reduced by a rolling or forging action against a mandrel, depending on size. Because this process uses rolls of strip stock as raw material and is best operated continuously, a flying saw is required to cut the tubing to correct length. Resistance butt welding may be done in a mill, but because of the relatively light equipment needed, it frequently is performed as a secondary operation in a fabricator's plant.

Some Pipe Welded with Filler Metal. For large sizes from about 15 cm (6 in.) to an unlimited upper limit that are needed in relatively small quantities, pipe may be manufactured by forming of plate or sheet and welding by any of the fusion processes. In practice, the *submerged-arc method*, discussed in Chapter 8, is often the most economical welding procedure. After the edges of the plate have been properly prepared by shearing or machining, the steps shown in Figure 7.11 are followed in forming the pipe.

A relatively small quantity of larger pipe, from about 4 to 75 cm (1.5 to 30 in.) in diameter, is *lap welded*. For this process, the skelp is beveled on the edges as it emerges from the furnace. It is then formed to cylindrical shape with overlapping edges. While at elevated temperature for welding, the tube is passed between a pressure roller and a mandrel for the establishment of welding pressure.

Spiral-Welded Pipe. The making of light-gage pipe or tubing as pictured in Figure 7.12 can be accomplished by resistance welding of a continuous spiral butt or lap joint. A principal advantage of the process is the light equipment required and the flexibility in changing from one size or one material to another. Any material that can be welded can be fabricated into pipe by this method.

Seamless Tubing. In practice, the term *seamless tubing* refers to a tubular product that is made without welding. The most common method used for steel involves *piercing* of round billets of relatively large cross section and short length, with subsequent deformation operations to control the final diameter, wall thickness, and length. Figure 7.13 shows the most common type of piercing mill used. The skew rollers both flatten and advance the billet with a helical motion. High shear stresses are developed at the center of the billet, at which point the material is forced over a bullet-shaped mandrel.

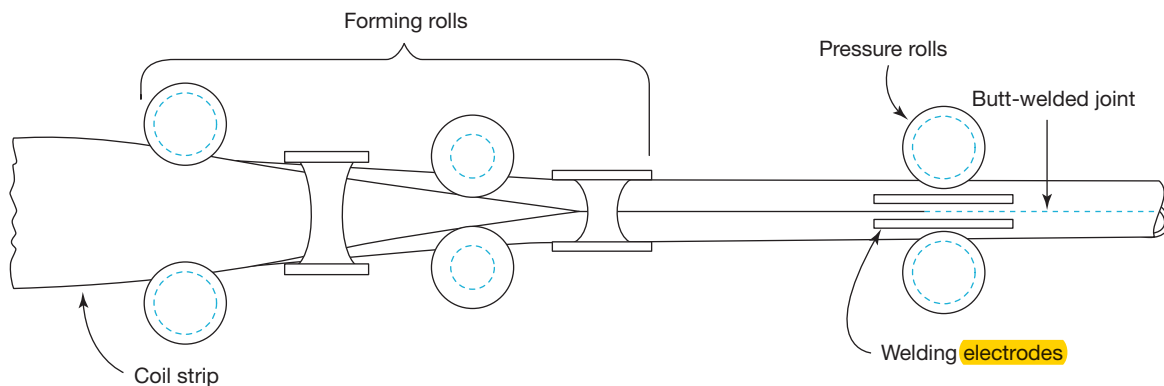

Figure 7.10: Resistance welding of tubing.

Overall Joint Efficiency High. While a small amount of fusion of the base metal may occur in some pressure bonds, it is incidental. No pronounced solidification shrinkage occurs as it does with fusion welds. Consequently, distortion after welding is usually very slight. The efficiency of pressure bonds, based on the original area, may be as high as 95%. Even though some inclusions are in the weld area, lowering unit strength, pressure-welded joints may actually be stronger than the original cross section as a result of the enlargement that occurs with plastic flow. This is especially true in butt-welding procedures as used in the manufacture of some chain links and fittings.

8.1.2.3 FLOW BONDING

Base Material Not Melted. When a filler material of different composition and lower melting temperature than the base metal is used, the mechanism is described as *flow bonding* (Figure 8.5). While some fusion of the base metal may occur, it is not essential to the process and is usually undesirable. The closeness necessary for bonding is established by the molten filler metal conforming to the surface of the base metal. The required cleanliness is produced by use of fluxes, ordinarily metal halides, or borax, which dissolve the surface oxides and float them out of the joint.

Joint Defined by Temperature and Spacing. Three different operations using flow bonds have been named: *braze welding*, *brazing*, and *soldering*. In braze welding, the filler material is a metal or alloy having a melting point above $449\text{ }^{\circ}\text{C}$ ($840\text{ }^{\circ}\text{F}$) and a composition significantly different from the base metal. In practice, the commonest alloys used as filler are copper or silver based. Occasionally, pure copper is used for braze welding steel. The filler is usually in rod form, and the procedures are similar to those employed in some fusion welding except that only the filler material is melted. Fluxes are heated on the joint surfaces for cleaning. Braze welding is used mainly for joining and repairing cast iron but is being replaced by fusion welding in many cases. The joint strength is limited to that of the filler material in cast form.

8.1.3 SOLDERING AND BRAZING

Both brazing and soldering are common and relatively economical methods of mechanically joining both similar and dissimilar metals with filler material. These processes require contact between mating surfaces as the filler material, when heated to slightly above its melting temperature, is drawn into the microscopic voids

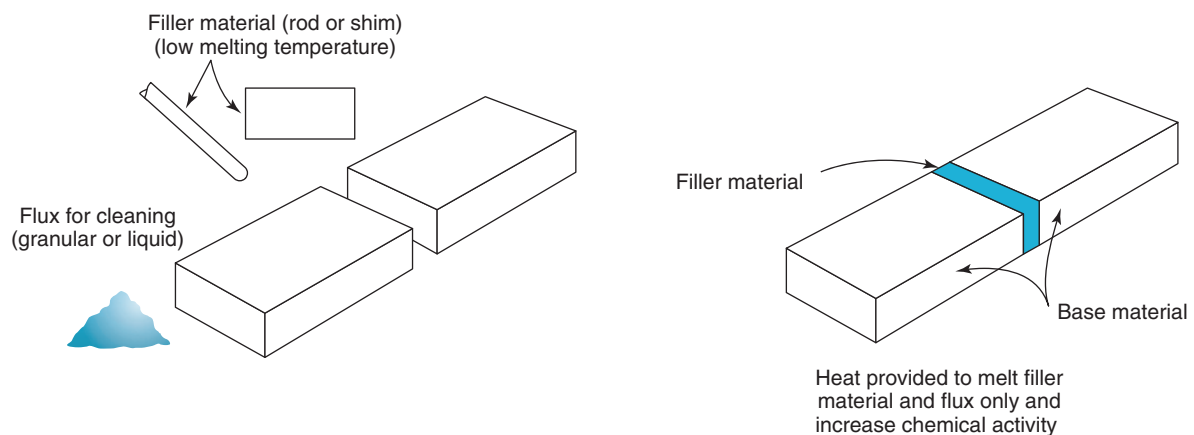

Figure 8.5: Flow bond.

the first critical angle at a water-aluminum interface, with 1.48 km/s and 6.3 km/s respective compression wave velocities, occurs when the incident sound field is oriented 13.59° off perpendicular. This is calculated using Snell's law as follows:

$$\frac{\sin \theta_1}{\sin \theta_2} = \frac{V_1}{V_2}$$

$$\sin \theta_1 = \sin \theta_2 \cdot \frac{V_1}{V_2}$$

(Eq. 12.5) $\theta_1 = \sin^{-1} \sin \theta_2 \cdot \frac{V_1}{V_2}$

$$\theta_1 = \sin^{-1} \sin 90^\circ \cdot \frac{1.48 \text{ km/s}}{6.3 \text{ km/s}}$$

$$\theta_1 = 13.59^\circ$$

The second critical angle is the incident angle at which the slower shear wave is refracted at 90°. In our water-aluminum example, a shear wave in gold propagating at 1.2 km/s would be refracted at 90°—this is the second critical angle—with an incident angle of 28.52°.

Use of Wedges. The incident angle of the sound field may be modified electronically and/or mechanically, for example, with water coupling and a variable angle-probe manipulator or with an angled wedge. Wedges are common on conventional single-angle transducers—for example, 45°, 60°, and 70°—and they are also useful in the higher-end phased array (PA) systems, also referred to as *phased array ultrasonic testing* (PAUT) systems. The wedge angle for single-angle probes is fabricated based on Snell's law to produce a shear wave within the test object at a desired angle. Recall that velocity, and consequently the angle, will change with temperature. Wedges for PAUT probes also have a particular angle, but these systems have the capability to alter the direction and shape of the sound field. PAUT systems can electronically sweep the sound field through a range of angles in what is known as a *sectorial scan*, focus the acoustic pressure at desired depths within the near field, and scan an area without moving the probe as in a linear scan.

12.4.2 MATERIALS, EQUIPMENT, AND TECHNIQUES

Ultrasonic testing techniques for nondestructive testing have three general purposes: (1) detection and characterization of discontinuities in materials, (2) evaluation of material properties or thickness, and (3) bond characterization. Techniques have been developed to economically evaluate large or small test objects of nearly every material type and across essentially every industry. Techniques may be divided by application, such as thickness gaging or discontinuity detection; by type of transducer, such as immersion, contact, or noncontact; by how the transducer is manipulated, that is, manual versus automated; and/or by the number and configuration of transducers used.

Heat can be described as the energy associated with the random and chaotic motions of the atomic particles which compose matter. Temperature is a measure of the intensity of particle motion in degrees celsius ($^{\circ}\text{C}$) or fahrenheit ($^{\circ}\text{F}$), or in the absolute scales of kelvin (K) or rankine ($^{\circ}\text{R}$). At a microscopic length scale, the thermal energy of a substance is the vibrational kinetic energy of its constituent atoms or molecules. Increased thermal energy causes increased vibration or motion. The atomic or molecular velocities are proportional to temperature, and the lowest point on the kelvin temperature scale where atomic/molecular motion essentially ceases—that is, absolute zero—indicates a thermal energy of zero. Heat always flows from a warmer to a cooler region, and it may be transferred between two points via conduction or convection within a substance and via radiation as the thermal motion of particles emits electromagnetic radiation.

Convection and Conduction. *Convection* is thermal energy transfer through the motion of fluids, which is the dominant transfer mode for liquids and gases, for example, heated air rising as a result of its lower density, while cooler air sinks. While convection is limited to fluids, conduction and radiation occur in all forms of matter: solid, liquid, gas, or plasma. *Conduction* is the transfer of thermal energy by diffusion and by collisions between constituents. All matter with a temperature greater than absolute zero (0 K or -273°C) emits thermal radiation. The total energy emitted, the peak wavelength, and the spectral energy distribution of this thermal radiation may be predicted mathematically based on the object's temperature. Total emitted energy and the energy of electromagnetic radiation photons emitted increase proportionally with temperature. The amount of radiated energy also varies with the material and surface properties of the specimen.

Emissivity and Blackbody Radiation. Emissivity is the ratio of total energy radiated by a specimen's surface at a given temperature, as compared with the total energy radiated by a blackbody radiator of the same temperature. A hypothetical *blackbody* emits the maximum radiation energy theoretically possible at a given temperature; consequently, it has an emissivity of 1.0. A blackbody would also absorb all incident radiation falling upon it. Emissivity is inversely proportional to reflectivity and is a key variable in IR.

All real materials have emissivities greater than 0.0 and less than 1.0. Poor understanding of emissivity will lead to poor measurement results. In other words, no real surface will absorb all incident radiation, so it will also emit less radiation than an ideal blackbody. Coatings, such as tape, carbon black, paint, or metallic surface treatments, alter a sample's emissivity. One example is low-emissivity glass, which uses a metallic coating to keep more thermal energy on the source side of the pane. The operator must be aware that discontinuities may be missed or obscured due to reflections, emissivity, or spatial variations due to the viewing angle or interference from wind, sunlight, moisture, or personnel.

12.12.2 EQUIPMENT AND TECHNIQUES

Contact and Noncontact Thermography. Infrared and thermal testing is the measurement or mapping of surface temperatures when heat flows from, to, or through a test object. *Contact thermography* techniques are available for mapping the temperature distribution of an area, possibly using a liquid crystal panel of the type that has been useful in medical applications to screen patients for deep-vein thrombosis. *Noncontact IR techniques* detect infrared wavelengths of electromagnetic radiation emitted by the test object. Noncontact techniques are useful for moving targets, when the target is in a controlled environment, such as in a vacuum or held within an electromagnetic field, and when the target temperature exceeds the capability of contact techniques.